

## Series universal AC generator: theory, operation and analysis

Y.G. Dessouky

Electrical and Control Eng. Dept., Arab Academy for Science and Technology,  
Miami, Alexandria, P.O. Box: 1029, Egypt

The series DC machine operates as a series DC motor or as a series universal AC motor when fed from a DC or an AC supply respectively. Series DC motors have been used in many industrial applications which require a high starting torque and a considerably adjustable range of speeds. Series universal AC motors are used in fractional horsepower ratings in many domestic appliances. The series DC machine also generates DC voltage when driven by a prime mover and connected to a DC load where the machine has rising voltage characteristics such that with increase in load its voltage is also increased and therefore it is normally used as a booster. In this paper, the series DC generator is operated as a series universal AC generator through an excitation capacitor. The armature winding, field winding, excitation capacitor and the load are connected in series. The voltage building up process takes place due to residual magnetism and the machine is self-excited and at steady state operates in the saturation region. The machine runs at resonance meaning that the generated induced emf is in phase with the armature current. The frequency of this machine is not synchronized with speed. The theory of operation is explained and the transient and steady state analysis are predicted and experimentally investigated.

تستخدم آلات التيار المستمر الموصلة بالتوالي كمحرك سواء تم تغذيتها بمصدر مستمر أو مصدر متردد. كذلك يمكن استخدام هذه الآلة كمولد لتوليد تيار مستمر. في هذا البحث تم اقتراح طريقة يمكن بها تشغيل آلة التيار المستمر الموصلة بالتوالي لتوليد تيار متردد من خلال مكثف سعوي حيث يتم بناء الجهد الكهربائي بفضل المغناطيسية المتبقية في الأجزاء الحديدية وفي حالة الاستقرار النهائي تعمل الآلة في مرحلة التشبع بتغذية ذاتية. يتم تشغيل الآلة في حالة رنين حيث يتحد تيار عضو الاستنتاج في الطور مع القوة الدافعة الكهربائية المتولدة بالحث من الآلة ويكون التردد غير معتمد على سرعة إدارة المولد. تم شرح نظرية عمل الآلة و استنتاج نموذج تحليلي للآلة و كذلك مقارنة النتائج المستنتجة من هذا النموذج مع تلك المقاسة من المعمل.

**Keywords:** Self-excited machine, Series machine, Universal machine, AC generator, Resonance

### 1. Introduction

Electric machines, namely DC, induction and synchronous generators are used for electro-mechanical energy conversion from mechanical form to electrical form according to the electromagnetic phenomena which states that when a conductor moves in a magnetic field, a voltage is induced in the conductor. In DC machines, the field winding is placed on the stator and the armature winding on the rotor. A DC current is passed through the field winding to produce a flux in the machine. Voltage induced in the armature winding is alternating. A mechanical commutator and a brush assembly function as a rectifier making the armature terminal voltage unidirectional. The DC machines are versatile and extensively used in industry [1]. Although a DC machine can operate as either

a generator or a motor, at present its use as a generator is limited because of widespread use of AC power [2]. In series DC generator, the field winding, armature winding and the load are connected in series. The voltage building up takes place due to residual magnetization and settles due to saturation such that, at steady state, the machine runs as a self excited machine where the operating point is the intersection point of the magnetization curve and the load characteristic [3]. The series DC machine can also operate as a motor when fed from an AC supply and the machine is then called series universal AC motor as it is widely used in fractional horsepower ratings in many domestic appliances [4]. The speed of the series universal AC motor is not synchronized with the supply frequency. Conversely, in this paper, the DC series machine is operated as a

series universal AC generator such that the armature winding and the series field winding are connected in series to both the load and excitation capacitor as shown in fig. 1. The theory of operation is explained and the dynamic model of the machine is derived. The performance equations are concluded and the steady state and transient analysis are predicted from the model and compared with the experimental results.

## 2. Theory of operation

If a conductor of length ' $l$ ' moves at a linear speed ' $v$ ' in a magnetic field density ' $B$ ' an induced voltage ' $e$ ' in the conductor is induced given by:

$$e = Blv . \quad (1)$$

Where  $l$ ,  $v$  and  $B$  are mutually perpendicular. The polarity of the induced voltage can be determined from the right-hand screw rule. With reference to fig. 2, in the simple loop series DC generator, since the field current is DC and the generator is rotating in one direction, the two vectors ' $B$ ' and ' $v$ ' for the conductors ' $ab$ ' and ' $cd$ ' will not change. That means the conductor facing the N-pole, whichever ' $ab$ ' as in fig. 2-a or ' $cd$ ' as in fig. 2-b, will have current direction upwards and that facing the S-pole will have downwards direction. Because of the commutator, the brush '1' is always positive and the brush '2' is always negative. For the proposed series universal AC generator and with reference to fig. 3, if an AC voltage is built up and an AC current will flow, since the field current is the armature current, because of series connection, they both will have the same frequency meaning that they both will change their direction at the same time. By applying right hand screw rule for both conductors ' $ab$ ' and ' $cd$ ' in the two positions of the coil ' $abcd$ ' shown in fig. 3-a and fig. 3-b, it is concluded that the armature and the field currents will change their direction and will have an AC nature and thus the energy conversion process can sustain.

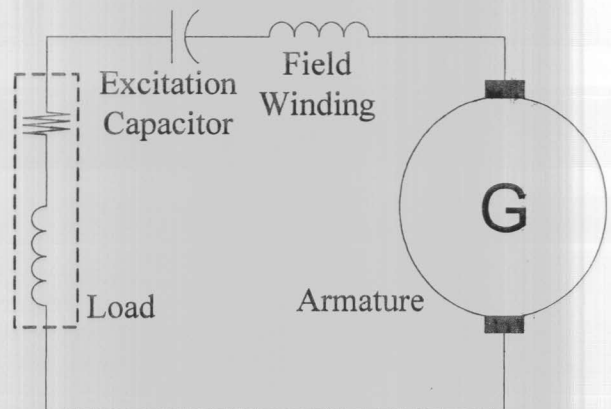

Fig. 1. Connection diagram of series universal AC generator.

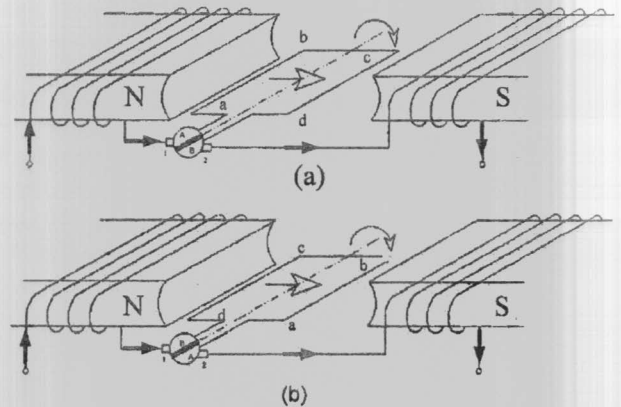

Fig. 2. Simple loop DC generator.

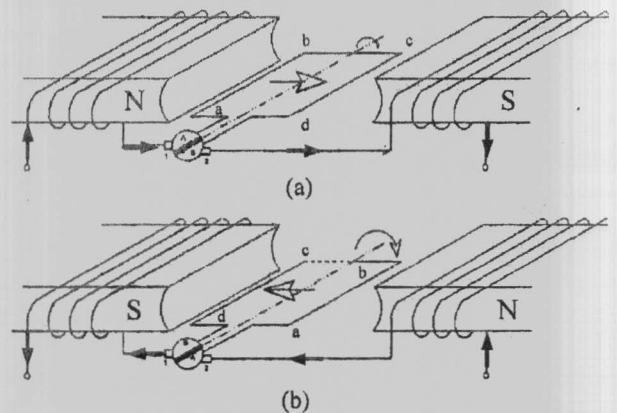

Fig. 3. Simple loop series universal AC generator.

### 3. Operation of the series universal AC generator

For a conventional DC machine, the armature winding is fully pitched around the armature circumference and the armature coil is considered perpendicular to the field winding [5]. If the machine runs as a series universal AC generator, and neglecting eddy current effects, the generated induced emf will be in phase with the field current and the armature current similar to the series universal AC motor. This implies that the machine should be running at resonance meaning that there should be an excitation capacitor to resonate with the equivalent inductance of the circuit consisting of field, armature and load. The frequency of the generated induced emf will not be synchronized with the speed. This means that this machine is not a synchronous machine. The voltage building up process takes place by the virtue of residual magnetization in the machine iron and the process stops when an equilibrium point is reached due to saturation in the magnetic circuit. Similar to series DC generator, in the series universal AC generator, the armature mmf reaction distorts the flux density distribution and produces a demagnetization flux causing poor commutation leading to sparking. A compensation coil can be connected in series with the armature to produce flux in opposition to the flux produced the current flowing through the armature. This results in increasing both induced emf, hence speed and the power factor hence efficiency. Because the armature current is AC, alternatively, a shorted compensation coil can be installed such that the induced current in the coil can oppose the armature reaction [6].

### 4. Model and dynamic equations

From the conventional no load test of the DC generator and by dividing the Y-axis in this curve by speed to normalize the current, the relationship between the generated induced emf per unit speed and the magnetization field current can be depicted. For the series universal AC generator, the same relation holds good between the

maximum values of generated induced emf and field current in both directions. With reference to fig. 4, the well-known dynamic equation of the DC machine is given by [7].

$$\begin{bmatrix} v_f \\ v_a \end{bmatrix} = \begin{bmatrix} R_f + L_f P & 0 \\ M_{fa} \omega_r & R_a + L_a P \end{bmatrix} \begin{bmatrix} i_f \\ i_a \end{bmatrix}, \quad (2)$$

where ' $P$ ' is differential operator and ' $M_{fa}$ ' is the speed mutual inductance between armature and field coil. Applying the conditions of series universal AC generator eq. (2) yields:

$$\begin{cases} e = M_{fa} \omega_r i_f = v_f + v_a + R_{af} i_a + L_{af} P i_a \\ v_f + v_a = L_L P i_a + R_L i_a + \frac{1}{C} \int i_a dt \end{cases}, \quad (3)$$

where,

$$R_{af} = R_a + R_f \quad \text{and} \quad L_{af} = L_a + L_f.$$

The MATLAB-SIMULINK software is used to simulate the series universal AC generator as shown in fig. 5. The generated induced emf is presented by a voltage source dependent on the field current such that their relationship is evaluated from conventional no load test. The internal impedance of the machine is represented by the equivalent resistance and inductance of both series field winding and armature windings. The excitation capacitor and the load may be connected in series or in parallel. In this paper, a series connection is analyzed as this machine is expected not to run without load so as to limit generator current. Also for series connection, at resonance, frequency will be independent on the resistive part of the load. If the load has no resistive part, the armature current is only limited by the resistance  $R_{af}$ . The capacitor-load combination is connected in series with field and armature winding as shown in fig. 5.

### 5. Steady state analysis

At steady state, the machine runs at resonance such that voltages and the current are sinusoidal and generated induced emf is in phase with the armature current and

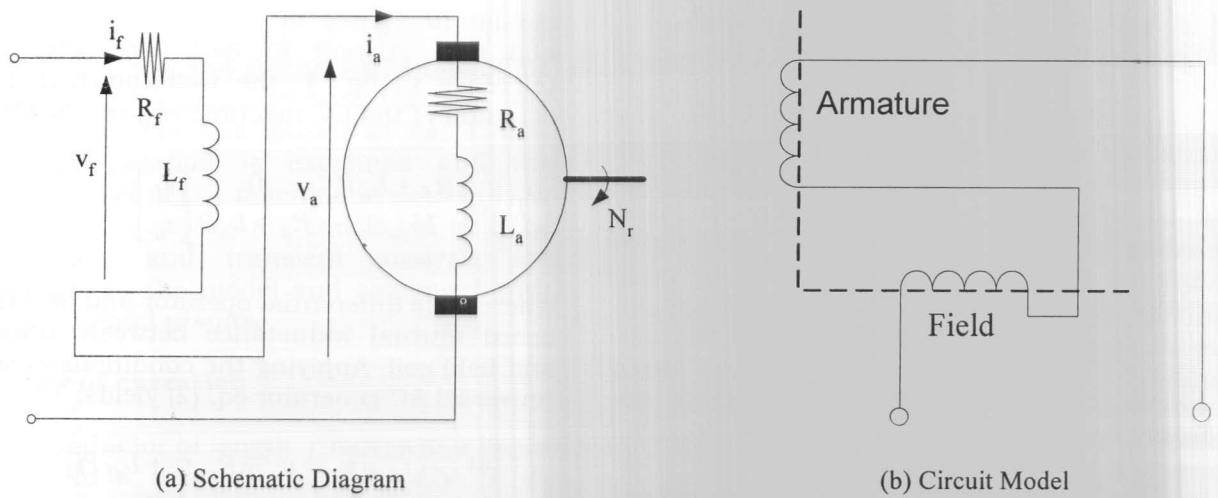

Fig. 4. Series DC Machine (as a motor).

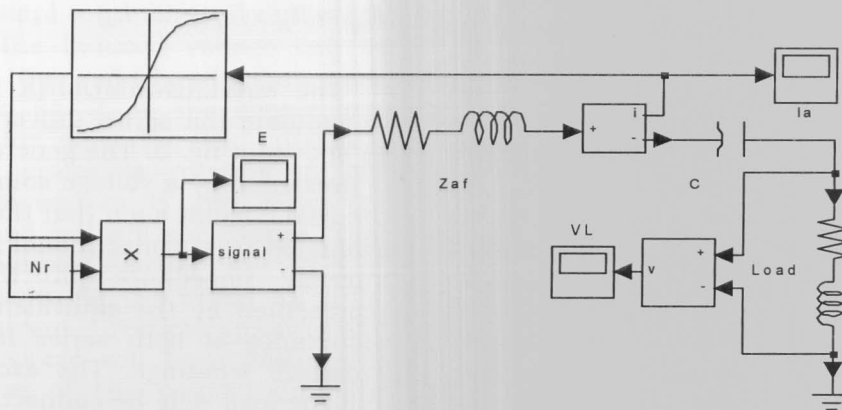

Fig. 5. Model of the series universal AC generator.

$$E \angle 0 = [R_{af} + R_L + j(X_{af} + X_L - X_c)] I_a \angle 0, \quad (4)$$

$$\omega_e = \frac{1}{\sqrt{C(L_{af} + L_L)}}. \quad (7)$$

that means:

$$X_{af} + X_L = X_c, \quad (5)$$

and

$$(L_{af} + L_L)\omega_e = \frac{1}{\omega_e C}. \quad (6)$$

The operating point is the intersection of the magnetization curve and the load characteristics. Thus if the magnetization curve during saturation is approximated to.

$$E = (a_3 I_a^3 + a_2 I_a^2 + a_1 I_a + a_0) \times N_R, \quad (8)$$

and the load characteristics are given by.

Therefore, the operating frequency is given by.

$$E = (R_L + R_{af})I_a \quad (9)$$

From eq. (8) and eq. (9), the operating point is the solution of the following equation.

$$a_3 I_a^3 + a_2 I_a^2 + (a_1 - \frac{R_L + R_{af}}{N_R}) I_a + a_0 = 0 \quad (10)$$

Having got the armature current ' $I_a$ ' from eq. (10), induced emf can be obtained from eq. (9) and the excitation capacitor and load voltages can then be obtained from the equivalent circuit of fig. 5.

There is a critical load resistance  $R_{LC}$  at which the slope of the load characteristics equals to the slope of linear part of the magnetization curve before saturation after which the self-excitation process fails such that.

$$R_{LC} + R_{af} = \frac{E_U}{I_U} \quad (11)$$

where

$E_U$  and  $I_U$  are the induced emf and current at saturation point. The resistance  $R_{LC}$  will be dependent on speed, since  $E_U$  is speed dependent.

## 6. Transient analysis

The equivalent circuit shown in fig. 5 can also be used to study the transient performance of the machine such that the process of voltage building up and changing driving speed, load and excitation capacitor can be studied. The residual magnetization is simulated by an initial voltage in the independent source.

## 7. Results

The proposed configuration is applied to the DC machine whose parameters are given in appendix (A). The relationship between RMS load voltage and current for a resistive load at steady state is shown in fig. 6 and 7 for different values of speed and capacitance respectively. Fig. 8 shows simulated building up process of the generated induced emf,

current and load voltage for a resistive load at a speed of 1250 rpm and excitation capacitor of 165  $\mu\text{F}$  while fig. 9 shows experimental load voltage building up at the same conditions. Fig. 10 shows the effect of change in driving speed on a resistive load voltage for excitation capacitor of 330  $\mu\text{F}$  and step change in speed from 1500 rpm to 1000 rpm while fig. 11 shows the effect of increasing load on voltage for a resistive load for capacitor of 330  $\mu\text{F}$  and speed of 1250 rpm. Fig. 12 shows the effect of change in excitation capacitor on load voltage and current for an inductive load for a speed of 1250 rpm and a step change in the excitation capacitor from 265  $\mu\text{F}$  to 330  $\mu\text{F}$ .

## 8. Discussion

- It could be concluded that load voltage depends on speed as shown in fig. 6-a and fig. 10, because the generated emf is speed dependent, see eq. (8) while the load voltage does not depend on the excitation capacitor as shown in fig. 7-a because the load is resistive which means that the generated emf is divided between the load and the resistance  $R_{af}$  where the generator runs at resonance, see eq. (9). Also, the operating frequency depends on excitation capacitor as shown in fig. 7-b but not on speed as shown in fig. 6-b and 10. For an inductive load, the generated induced emf and the armature current would not change with excitation capacitor but the load voltage would because the frequency does change and consequently the impedance then the load voltage for the same load current. However, for this particular machine, the frequency is already low and the change in load inductive reactance is not noticeable and so is the load voltage. This is shown in fig. 12-a.
- It should be noted that although the generator emf is flat topped due to saturation as shown in fig. 8-a, the load current and hence voltage are sinusoidal as shown in fig. 8-b and fig. 8-c as the machine impedance would act as a low pass filter.
- The magnitude of the generated induced emf is dependent on speed like conventional DC machine but the frequency should not depend on the speed nor the number of poles because the armature coil is considered

perpendicular to the field winding no matter how many poles does the machine have.

- The hysteresis losses could be represented by simulating the B-H curve hysteresis curve of the machine in the model of fig. 5 instead of the conventional steady state no load test. This would result in not running the machine at resonance as the armature current would be lagging the generated induced emf. The frequency would then be dependent on excitation capacitor, speed and loading and the model would be more complex. This explains the deviation between theoretical and experimental test of fig. 6-b.

- The prototype machine was not designed to run in this mode of operation. Because the frequency of the output voltage is dependent on the machine parameters and the machine runs at the saturation, another study is needed to analyze the effect of machine parameters on the performance. A well-designed machine would give more promising results.

- The synchronous, induction and DC machines can generate AC voltages when driven by a prime mover. The three machines can be compared from the point of views shown in table 1.

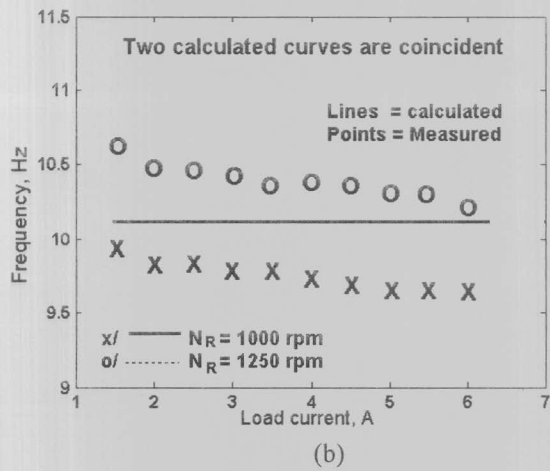
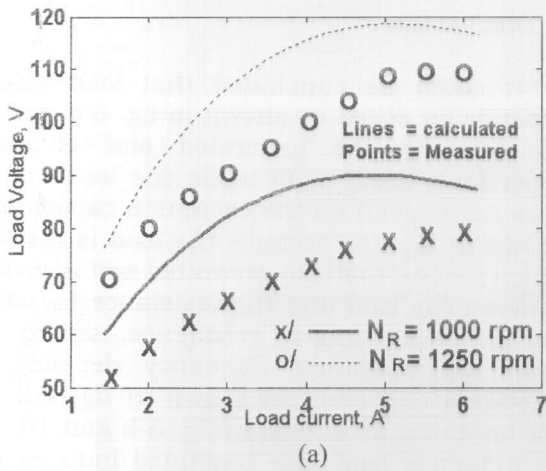

Fig. 6. RMS load voltage and current for  $C = 330 \mu\text{F}$  and (a)  $N_R = 1000$  rpm, (b)  $N_R = 1250$  rpm.

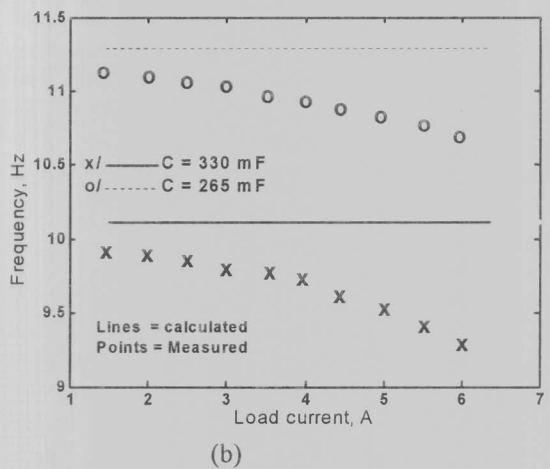
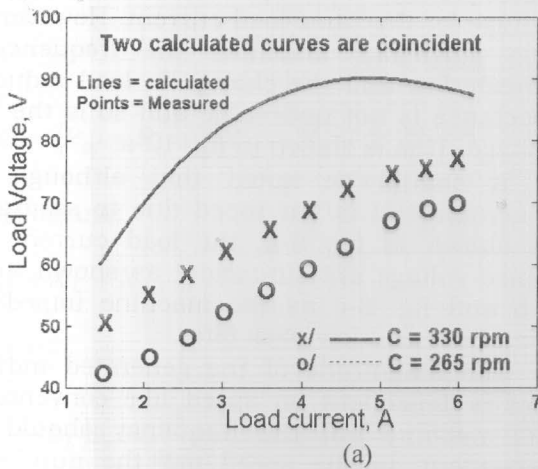

Fig. 7. RMS load voltage and current for  $N_R = 1000$  rpm and (a)  $C = 330 \mu\text{F}$ , (b)  $C = 265 \mu\text{F}$ .

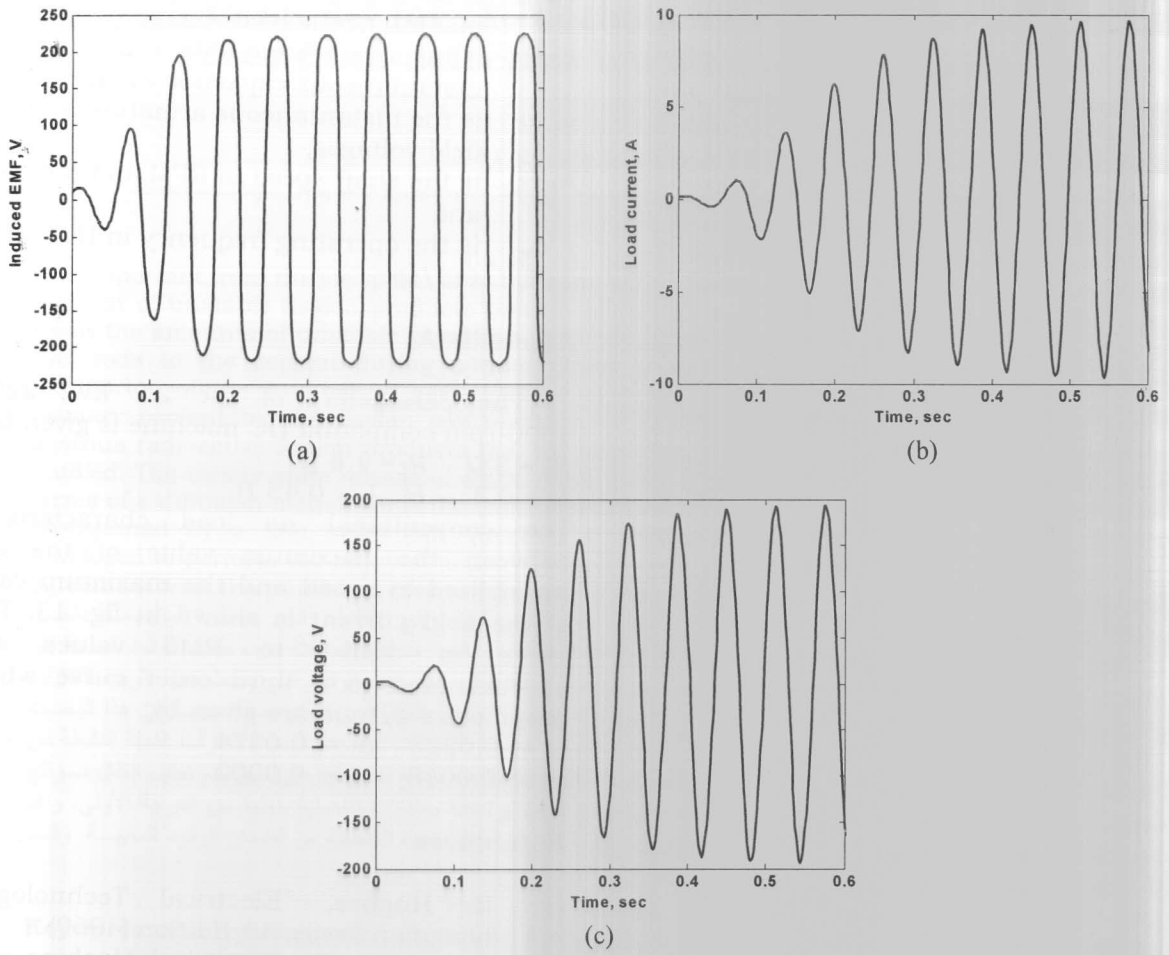

Fig. 8. Simulated (a) induced emf, (b) current and (c) load voltage during building up.

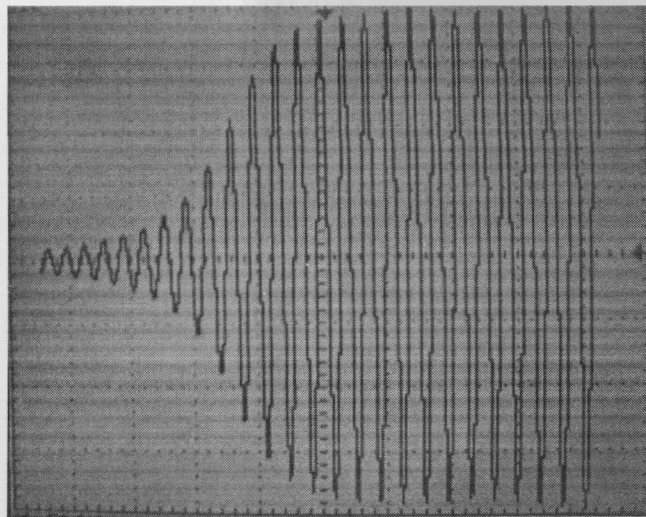

Fig. 9. Experimental load voltage during building up [50V/div and 0.2 sec/div].

## 9. Conclusions

The conventional series DC machine is a bidirectional energy conversion device. As a motor, a DC or AC electrical power can be applied and the machine is working as a self-excited series DC motor or a series universal AC motor respectively. As a generator, a DC or AC electrical power may be obtained and the machine is running as a self-excited series DC generator or a series universal AC generator respectively. To run the machine as a series universal AC generator, an excitation capacitor is needed to resonate with the inductance of the machine and the load. The generated induced emf is in phase with the field current and the frequency of the generated induced emf is not synchronized with the machine. The magnitude rather than the frequency of the generated emf is dependent on speed. The voltage building up process takes place by virtue of residual magnetism in the iron. The operating point at steady state is the intersection of the magnetizing curve and the load characteristic. There is a critical load resistance after which self-excitation process fails when the slope of the load characteristics equals to slope of liner part of the magnetization curve. The dynamic equations are concluded and the model of the machine is predicted. The steady state and transient performance are analyzed based on the machine model and the simulated results showed satisfactory matching when compared with the experimental results.

### List of symbols

$R_a, L_a$  is the armature resistance and inductance,  
 $R_f, L_f$  is the field resistance and inductance,  
 $R_L, L_L$  is the load resistance and inductance,  
 $C, X_C$  is the excitation capacitance and reactance,  
 $I_a, i_a$  is the steady state RMS and instantaneous armature current,  
 $I_f, i_f$  steady state RMS and instantaneous field current,  
 $I_L, i_L$  is the steady state RMS and instantaneous load current,  
 $E, e$  is the steady state RMS and instantaneous induced emf,

$V_L, v_L$  is the steady state RMS and instantaneous load voltage,  
 $V_C, v_C$  is the steady state RMS and instantaneous capacitor voltage,  
 $v_a, v_f$  is the instantaneous armature and field voltages,  
 $N_R, \omega_r$  is the shaft speed in RPM and rad/sec, and  
 $f, \omega_e$  is the operating frequency in Hz and rad/sec.

### Appendix A

The parameters of the 2.2 kW, 220V, 1500-rpm compound DC machine is given by:

$$R_a = 3 \Omega \quad R_f = 1.8 \Omega$$

$$L_a = 0.3 \text{ H} \quad L_f = 0.45 \text{ H}$$

The conventional no load characteristics between the maximum value of the emf normalized to speed and the maximum value of the field current is shown in fig. 13. This curve is scaled to RMS values and approximated to a third order curve whose parameters  $a_0$  to  $a_3$  are given by:

$$a_0 = 0.0223 \quad a_1 = 0.0374$$

$$a_2 = -0.0048 \quad a_3 = 0.0002$$

### References

- [1] E. Hughes, "Electrical Technology", Longman Press, 4<sup>th</sup> Edition (1960).
- [2] J. Hindmarch, "Electrical Machine and Their Applications", Pergamon Press, 4<sup>th</sup> Edition (1997).
- [3] Ivanov-Smolensky, "Electrical Machines", MIR Publishers, 2<sup>nd</sup> Printing (1988).
- [4] P.C. Sen, "Principles of Electric Machines and Power Electronics", John Wiley and Sons, 2<sup>nd</sup> Edition (1997).
- [5] R. A Pearman, "Electrical Machinery and Transformer Technology", Saunders College Publishing (1994).
- [6] A.E. Fitzgerald and C. Kingsley, "Electric Machinery", McGraw-Hill Book Company, INC.
- [7] G.J. Thaler and M.L. Wilcox, "Electric Machines: Dynamic and Steady State Analysis", John Wiley and Sons, INC, (1996).

Received February 18, 2006  
 Accepted November 20, 2006