

Ultimate strength and load carrying capacity of a telescopic crane boom

M. A. Shama and Y. A. Abdel – Nasser

Dept. of Naval Architecture and Marine Eng., Faculty of Eng., Alexandria University, Alexandria, Egypt

The demand for great reliability, economy and maximum lifting capacity of a telescopic crane requires an accurate structural design for the box girder of the crane boom. A telescopic crane boom should have adequate scantlings in addition to a minimum weight to fulfill its function. In this work different configuration of stiffening arrangements are suggested for the box girder of the crane boom. The behavior of the box girder for each configuration is investigated until the ultimate strength state. The ultimate bending moment of the box girder due to progressive failures of buckling and yielding modes is calculated by using the Finite Element Method (FEM). Several analyses are executed to select the optimum configuration that satisfies maximum lifting capacity and less boom weight. A design graph is developed to determine the maximum carrying load of the telescopic crane for different boom lengths and the lifting angles.

تلعب الأوناش بكافة أنواعها دوراً أساسياً في تطوير عملية نقل البضائع المختلفة في المجال البحري. في هذا البحث تم تناول ودراسة التصميم الإنشائي لبومة الونش التلسكوبي. حيث أن التصميم الأمثل لبومة الونش يساعد على تقليل وزن البومة وزيادة طاقة رفع الونش وتحقيق الأمان المطلوب له. اقترحت عدة أشكال إنشائية جديدة لتقوية بومة الونش عند تعرضها لأحمال الانحاء. تم حساب مقاومة الانحاء القصوى لهذه المقاطع المختلفة وذلك باستخدام طريقة العنصر الموحد. بناءاً على مقاومة الانحاء القصوى تم اختيار المقطع الأمثل الذي يحقق أقصى طاقة رفع لبومة الونش. أخذ في الاعتبار عند حساب طاقة رفع الونش طول البومة وزاوية الرفع.

Keywords: Telescopic crane boom, Box girder, Overlap welding, Ultimate bending moment, Maximum lifting capacity

1. Introduction

Telescopic cranes play an important role in ports for cargo /containers/ loading and unloading. They may fulfill a number of functions; mainly the transportation and the stacking of containers. A telescopic crane boom should have adequate scantlings to fulfill its function. Heavy loads will require extensive stiffening arrangements for the crane boom. Therefore, an accurate structural design of the crane boom is significant to achieve an optimum design having less boom weight and maximum lifting capacity. Marine services have recorded cases of catastrophic failures for telescopic crane booms [1]. Most of these failures are due to inadequate strength against both buckling and yielding of the boom box-girder. Therefore, three basic types of structural failures; namely plastic deformation, instability, and fracture should be examined. The interaction among these failure modes cannot be dealt with due to its complexity. The most common serious case is due to progressive failures of buckling and

yielding [2]. Therefore, the ultimate bending moment of the box girder of the crane boom when subjected to the maximum bending moment should be considered.

The objective of this work is to maximize the ultimate bending moment of the telescopic crane boom with reference to minimum boom weight. In shipbuilding industry, increasing the ultimate bending moment of a box girder are achieved by using stiffened plate panels or corrugated plates [3,4]. However, these stiffening arrangements will restrict movement and sliding of mechanical parts inside the telescopic booms. Therefore, a smart stiffening system by using overlap welded strips to plate panels of the box girder is preferred [5]. Different arrangements for stiffening the box girder with overlap welded strips are proposed. Thus, the behavior of the box girder for each configuration is analysed using the Finite Element Method (FEM)[6]. A case study of a typical telescopic crane boom is suggested to simulate the action of the maximum lifting weight. Hence, the optimum configuration of the box girder that satisfies

the maximum lifting capacity may be defined. A design graph is developed to determine the maximum carrying load for different boom lengths and lifting angles.

2. General behavior of a plate panel with overlap welded strips

Reinforcement of a plate panel with overlap welded strips is adopted in order to increase the stiffness and the ultimate strength of the plate panel. Based on the known behavior of the buckled plate panel under uniaxial compression, it is found that the out of plane deflection may be reduced when strips are overlap welded to the plate panel in the same direction of the acting load. Strictly speaking, when the strips have sufficient dimensions and proper locations, the developed deflection is significantly decreased and the plate ultimate strength is increased [7,8].

Several analyses have been carried out using the FEM program to examine the effect of strips locations and dimensions on the strength of the plate panel. For simplicity, a rectangular plate panel of 1000x500x5 mm and with yield strength equals to 25 kg/mm² is studied. Two strips are overlap welded to the long sides of the plate panel in the same direction of the acting load. Each strip has a breadth "b_s" and plate thickness "T_s". The plate panel is assumed to be simply supported around its edges and subjected to a uniaxial compression. Fig. 1 shows the deflected shape of the plate panel with and without plate strips. At the beginning, the stiffness of the plate panel is behaving linearly. With increasing the acting load the deflection increases leading to a reduction in the plate stiffness. With further increase of load, the plastification constitutes in the buckled plates, whereas higher stresses are developed until reaching to the ultimate strength. It is obvious from fig. 2 that the plate panel stiffened with overlap welded strips increase the ultimate strength of the plate panel. Also, the ultimate strength of the plate panel is highly increased when the dimensions of the overlap welded strips increase.

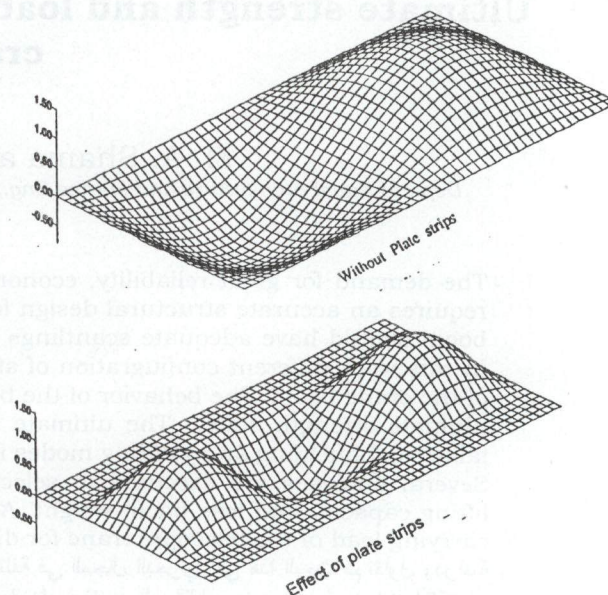

Fig. 1. Deflection shape of the plate panel.

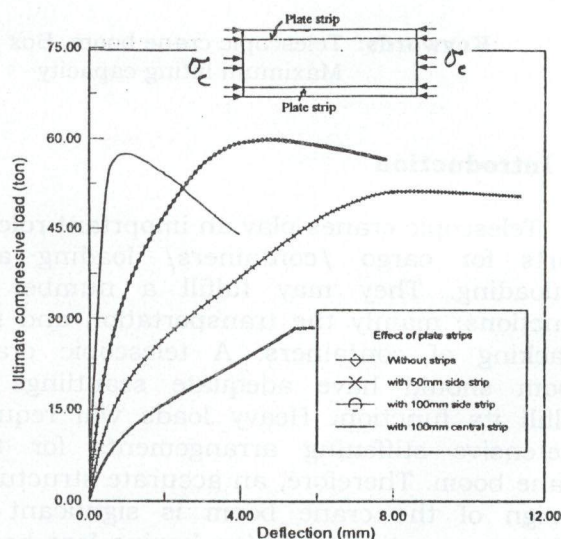

Fig. 2. Ultimate moment-deflection relationship of the plate panel.

3. General behavior of a box girder under bending moment and shear

The main structural components of a box girder consist of horizontal and vertical plate panels. Excessive and heavy scantlings may be required for stiffening these plate panels. The ultimate bending moment of the box

girder is based primary on the ultimate strength of the stiffened plate panels [9]. This in turn is influenced by the interaction of different failure modes such as buckling, yielding and fracture. Moreover, the strength against each failure mode is influenced by initial deflections, residual stresses, corrosion and fatigue cracks [10]. Only the ultimate bending moment due to progressive failures of buckling and yielding is evaluated.

In the following example, three box girders having different scantlings and weights are analyzed to evaluate their ultimate bending moment under the action of a bending moment. The used material has yield strength equal to 25 kg/mm². The scantlings and weight per unit length for each box girder are shown in fig. 3. Applying increasing axial compressive forces or displacement upon plates above the neutral axis and axial tensile forces or displacement upon plates below the neutral axis of the section simulates the acting bending moment. Fig. 4 shows the behavior of each box girder until it attains its ultimate bending moment. The collapse of the box girder is reached when the acting bending moment, M_a , exceeds the plastic moment, M_p . The failure equation is given as follows;

$$M_a > M_p \quad (1)$$

It is obvious from fig. 4 that the box girder without overlap welded strips and posses the lightest weight predicts the least ultimate moment, while that having the heaviest weight reaches to the maximum ultimate moment. The optimum design is that which stiffened with overlap welded strips. It attains a satisfactory ultimate bending moment with slightly increase in the weight of the box girder.

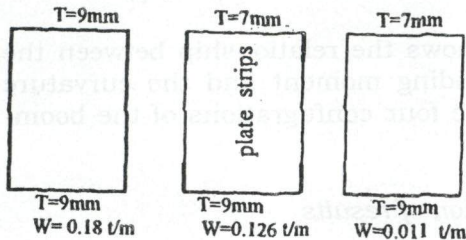

Fig. 3. Scantlings and weights per length for different box girders.

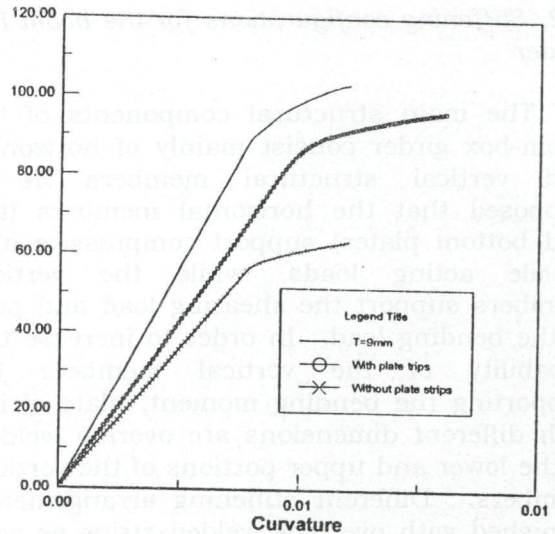

Fig.4 Ultimate moment-curvature relationship of the box girder.

4. Ultimate bending moment of the telescopic crane boom

4.1. The telescopic crane

The telescopic crane is widely used in marine service [11]. It fulfills several functions at ports. It is characterized by both maximum lifting capacity and outreach. The optimum design of the telescopic crane should give maximum lifting capacity and minimum boom weight. This requires innovative mechanical and structural design for the crane boom. Fig. 5. illustrates a typical profile of the selected telescopic crane boom. The commonly adopted telescopic crane consists of 4-bays to achieve the required outreach. The configuration of each bay is a uniform box girder. The first bay is the largest one, followed by smaller successive bays. Each bay could slide inside the previous bay using mechanical/ hydraulic system.

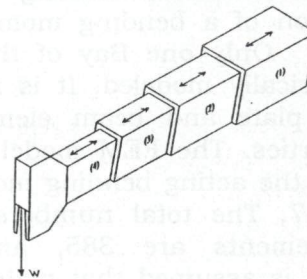

Fig. 5. Typical profile of the telescopic crane boom.

4.2. Stiffening configurations for the boom box girder

The main structural components of the boom-box girder consist mainly of horizontal and vertical structural members. It is supposed that the horizontal members (top and bottom plates) support compressive and tensile acting loads, while the vertical members support the shearing load and part of the bending load. In order to increase the capability of the vertical members for supporting the bending moment, plate strips with different dimensions are overlap welded to the lower and upper portions of the vertical members. Different stiffening arrangements furnished with overlaps welded strips as well as rolled sections are proposed to reinforce the boom box-girder as shown in fig. 6. It is assumed that each configuration holds the same weight (0.112t/m).

The different configurations of the boom box-girder are suggested as follows:

(M1): Two vertical C-sections, each one is overlap welded with unequal depths of plate strips. The plate strips are welded with the horizontal plates at top and bottom of the boom-box girder.

(M2): Four corner angles are used to assemble four plates that compose of the boom-box girder.

(M3): Two horizontal C- sections are overlap welded with vertical plates at sides of the boom-box girder.

(M4): As same as (M2) except that depths of lower and upper plate strips are equal.

4. 3. Examples of analyses

A FEM program is executed for each stiffening arrangement of the boom-box girder to evaluate its ultimate bending moment under the action of a bending moment and shearing force. Only one Bay of the crane boom is numerically modeled. It is idealized with different plate and beam elements of different properties. The FEM model for the box girder and the acting bending moment is shown in fig. 7. The total numbers of the nodes and elements are 385, and 330, respectively. It is assumed that plates made

from special steel of yield strength equal to 32 kg/mm².

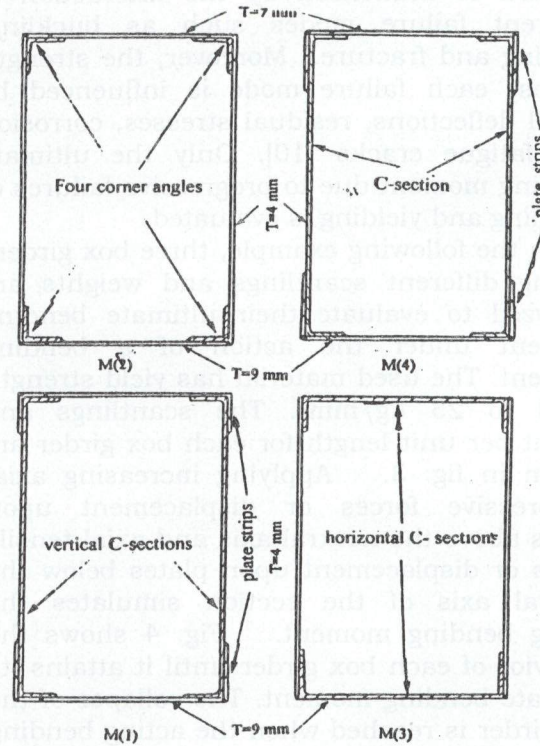

Fig. 6. Proposed configurations of the boom box girder.

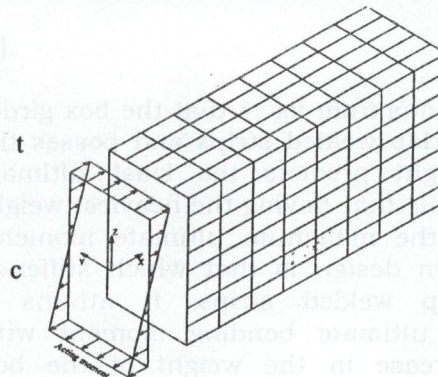

Fig. 7. FEM model of the crane boom (one bay).

Fig. 8 shows the relationship between the ultimate bending moment and the curvature for the above four configurations of the boom-box girder.

4.4. Discussion of results

Some important observations may be made from the results of the previous analyses as follows:

1. In all configurations, the bottom plate is firstly buckled accompanied with non linear stress distribution. With increasing load, plastification constitutes in the plate followed by its collapse. Therefore, a reinforcement of the bottom plate is needed to cope with the high compressive stresses by increasing its thickness.

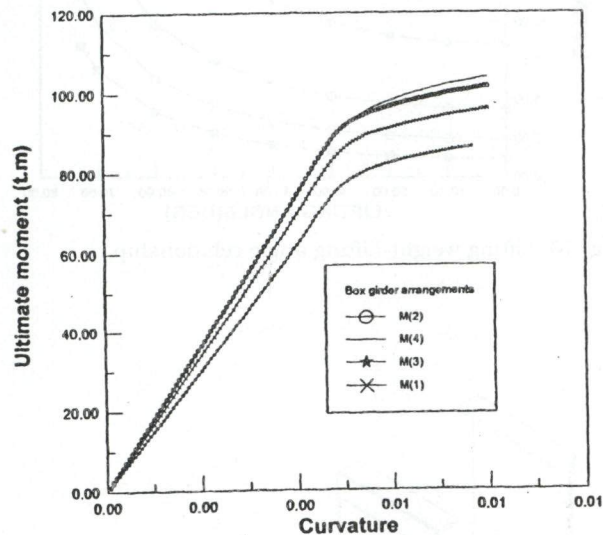

Fig. 8. Ultimate moment-curvature relationship of the crane boom.

2. The magnitude of the ultimate bending moment of the boom-box girder stiffened with overlapped welded strips is highly affected with two factors, namely depth and location of overlapped welded plate strips. The boom-box girder stiffened with deeper and vertical location of plate strips may support the highest ultimate moment (M4).

3. The configuration possessing vertical C-sections support higher shear force than that possessing horizontal C-sections. Therefore, the boom-box girder with horizontal C-sections attains the lowest ultimate bending moment (M3).

4. Small difference of the ultimate bending moment is observed for (M2) and (M4). This is because the two models have almost the same structural properties.

5. A small increase in the thickness of the vertical plate strips will not highly affect the ultimate bending moment. However, increasing the depth of plate strips will increase significantly the ultimate moment.

It is obvious from the above analyses and from fig. 8 that the crane boom constructed with vertical C-sections and overlap welded strips will be capable of lifting the highest weight. The optimum scantlings of this arrangement are as shown in fig. 9.

5. Maximum lifting capacity of the crane boom

After the ultimate bending moment had been calculated and the configuration of boom-box girder is optimized, the maximum lifting weight that the crane boom could carry is determined. As mentioned before the lifting weight is inversely proportion with the boom length and the working radius. When the working radius decreases, the capacity of the crane boom for lifting weight increases. The maximum weight to be carried by the boom could be determined as follows:

$$P = [M / (L \cos \alpha) - w / 2]. \quad (2)$$

Where:

P is the lifting weight, ton,

M is the ultimate bending moment, t.m,

w is the steel boom weight, ton (it excludes weight of mechanical parts),

L is the boom length, m,

α is the lifting angle and

W_r is the working radius = $L \times \cos \alpha$.

The calculated total rated loads shown in fig. 10 are based on the conditions that the crane is set firm on the ground horizontally. It is also assumed that the whole boom length (four bays) acquires the optimum scantlings of the configuration (M4). In order to increase the lifting capacity of the crane boom, particularly when the boom is fully extended, the scantlings of the first bay and the successive bays are increased gradually by adopting scantlings larger than that of the optimum configuration. The optimum configuration is erected on the last bay of the crane boom.

6. Sequence of operations for assembling the boom box-girder

In spite of selection the optimum boom-box girder that fulfills the required ultimate

bending moment. Fabrication and assembling operations have a considerable affect on the strength of the box girder. The structure that acquires initial imperfections (deflection and residual stresses) will attain a lower ultimate bending moment. Therefore, it is preferred to follow sequence of operations for assembling the boom box-girder in order to maintain its structural capability. These are assumed as follow, see fig. 11.

1. Rolled C-section with the proper dimension firstly is prepared (st:1).
2. Two vertical strips (lower and upper strips) are overlap welded to the web of C-section. An intermittent welding with a suitable pitch is preferred (st:2&3).
3. Similarly, prepare the opposite C-section with the two vertical strips (st:4).
4. Weld the bottom plate with the C-section. The direction of the overlap welding is opposite to the welding of C-section with the lower strip in order to increase the resisting shear area and also to reduce the welding distortion [12].
5. Weld the lower strip with the bottom plate. Continues and full penetration of welding is recommended (st:5).
6. Similarly, weld the opposite C-section to the bottom plate as explained before.
7. Tick weld the C-sections to the top plate.
8. Weld the upper two strips to the top plate. Continues and full penetration of welding is recommended (st:6).

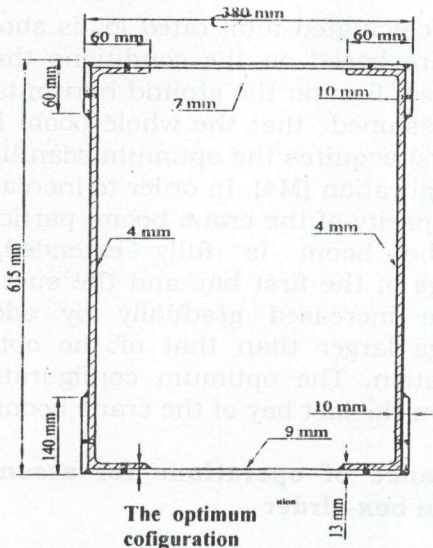

Fig. 9. Optimum configuration of the boom cross section.

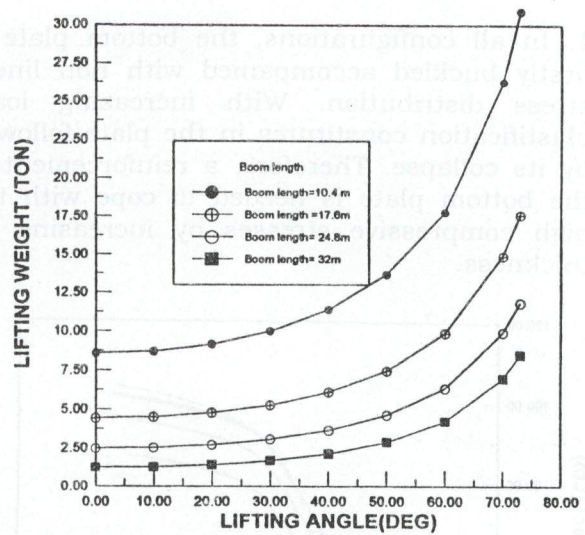

Fig. 10. Lifting weight-Lifting angle relationship.

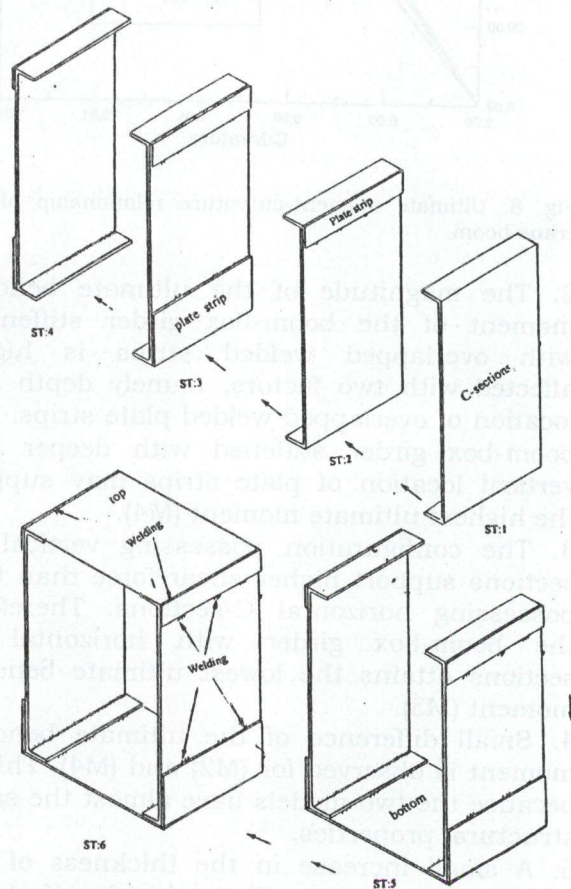

Fig. 11. Sequences of assembly of the boom's box girder.

7. Conclusions

The ultimate bending moment of a telescopic crane boom is investigated. The behavior of one bay of the crane boom under an acting lifting weight is analyzed until the ultimate strength state using a FEM code. Different arrangements for reinforcement the boom box-girder are studied in order to select the optimum configuration that fulfills maximum lifting capacity. Current study revealed the followings:

1. The boom box-girder needs reinforcement with overlap welded strips in order to increase its ultimate moment with holding the minimum boom weight. The box girder stiffened with deeper and vertical strips will support the highest ultimate moment.
2. An optimum configuration for stiffening the crane boom and satisfying maximum ultimate strength is proposed. This configuration is assumed to be erected in the last bay of the telescopic crane boom.
3. The operations for assembling the box girder may influence upon its ultimate bending moment. Therefore sequence of operations during assembly of the box girder is recommended in order to maintain its ultimate strength.
4. A combined shear force and acting moment reduce the ultimate bending moment and in turn the lifting weight. In order to increase the lifting capacity of the crane boom, particularly when the crane boom is fully extended, the scantlings of the first bay and the successive bays may be increased gradually by adopting scantlings larger than that of the optimum configuration.

References

- [1] R.G. Bee, "Ship Structure Maintenance: Recent Research Results and Experience", *Trans IMare*, Vol 105 (5), pp. 233-261 (1993).
- [2] O. Hughes, "Ship Structural Design: A rational-based Computer Aided Optimization", Publ. By John Wiley, N.Y. (1983).
- [3] Y. Bai, E. Bendiksen, and T. Pedersen, "Collapse Analysis of Ship Hulls", *Marine Structures*, Vol. 6, pp. 485-507 (1993).
- [4] D. Ricardo, "Ultimate Bending Moment of The Ship Hull Girder", Publ. in Cetena S.P.A. Genova, Italy (1999).
- [5] T. Hamasaki, "Development of Design and fabrication Method for Thin steel Plate Structure and Its Application to a Passenger Ship", *Journal of Ship Research*, Vol. 7 (2), pp. 128-135 (1991).
- [6] H. Murakawa, "Elastic-Plastic Analysis of a rectangular Plate by The Finite Element Method: A Computer program for Nonlinear Analysis", *Welding Research Institute, Osaka University, Japan*, (private Note) (1987).
- [7] Y. Ueda, S.M.H. Rashed and Y. Abdel-Nasser, "On Buckling Accepted Design of Ship Structures Utilizing HTS" *Jl. of Society of Naval Architects of Japan*, Vol. 171 (1992).
- [8] Y.A. Abdel-Nasser, and A.M. Rashwan, "A New Buckling Prevention Technique for Plate Panels constructed with Higher Strength Steel (Report 1)- Plate Panels Subjected to Uniaxial Compression", *Alexandria Engineering Journal*, Vol. 36 (1), Jan. (1997).
- [9] Y. Ueda and T. Yao, "Effect of Welding Residual Stresses and Initial Deflection on Rigidity and Strength of Square Plates Subjected to Compression" *Transactions of JWRI*, Vol. 4 (2) (1975).
- [10] G. Soares, and Y. Garbatov, "Reliability of Maintained Ship Hull Subjected to Corrosion", *Journal of Ship Research*, Vol 40 (3), pp.235-243 (1996).
- [11] "Specifications of A Telescopic Crane - Tando-TG-350M" special note
- [12] R. Glasfeld, D. Jordan and D. Zoller, "Structural Details Design Review", U.S. Coast Guard Headquarters, Washington, D.C. (1977).

Received August 8, 2001
Accepted January 8, 2002

- [3] Y. Hat, A. Bekdasoglu, and T. Fedorov, "Collapsing Analysis of Ship Hulls," *Marine Structures*, Vol. 6, pp. 883–897 (1993).
- [4] D. Ricardo, "Ultimate Bending Moment of The Ship Hull Girders," *Publ. in Ocean*, 3, P. A. Genova, Itak (1992).
- [5] T. Hattarada, "Development of Design and Fabrication Method for Thin steel Plate Structure and Its Application to a Passenger Ship," *Journal of Ship Research*, Vol. 7 (2), pp. 128–133 (1991).
- [6] H. Muskawa, "Elastic-Plastic Analysis of a Rectangular Plate by the Finite Element Method: A Computer program to Poststress Analysis," *Welding Research Institute, Osaka University, Japan*, (private Note) (1987).
- [7] Y. Ueda, E.M.H. Rashid, and Y. Abdelhaseeb, "On Buckling Accepted Design of Ship Structures Under HTS," *J. of the Society of Naval Architects of Japan*, Vol. 171 (1992).
- [8] V.A. Abdelhaseeb, and A.M. Rashwan, "A New Buckling Prevention Technique for Plate Panels Constructed with Higher Strength Steel (Report I) - Plate Panels Subjected to Uniaxial Compression," *Alexandria Engineering Journal*, Vol. 36 (1), Jan (1997).
- [9] Y. Ueda and T. Yano, "Effect of Welding Residual Stresses and Initial Deflection on Rigidity and Strength of Square Plates Subjected to Compression," *Transactions of JWI*, Vol. 4 (2) (1975).
- [10] O. Saeed, and Y. Garbatov, "Reliability of Manufactured Ship Hull Subjected to Corrosion," *Journal of Ship Research*, Vol. 40 (3), pp. 233–243 (1996).
- [11] "Specifications of A Telescop Crane - Yando TO-350M," special note.
- [12] R. Olsfeld, D. Jordan and D. Zoller, "Structural Details Design Review," US Coast Guard Headquarters, Washington, D.C. (1977).

Received August 8, 2011
Accepted January 2, 2013

7. Conclusions

The ultimate bending moment of a telescop crane boom is investigated. The behavior of one bay of the crane boom under an acting lifting weight is analyzed with the ultimate strength state using a FEM code. Different arrangements for reinforcement the boom box-girders are studied in order to select the optimum configuration that fulfills maximum lifting capacity. Current study revealed the following:

- The boom box-girders needs reinforcement with overlap welded strips in order to increase the ultimate moment with holding the minimum boom weight. The box girder stiffened with deeper and vertical strips will support the highest ultimate moment.
- An optimum configuration for stiffening the crane boom and satisfying maximum ultimate strength is proposed. This configuration is assumed to be erected in the last bay of the telescop crane boom.
- The operations for erecting the box girder may indicate upon its ultimate bending moment. The order sequence of operations during assembly of the box girder is recommended in order to maintain its ultimate strength.
- A compound steel face and string moment reduce the ultimate bending moment and to turn the lifting weight in order to increase the lifting capacity of the crane boom. It is particularly when the crane boom is fully extended, the sequence of the first bay and successive bays may be increased gradually by adopting spacings larger than that of the optimum configuration.

References

- [1] R.G. Bee, "Ship Structure Maintenance: Recent Research Results and Experience," *Trans Imine*, Vol. 105 (5), pp. 333–361 (1993).
- [2] O. Jorgens, "Ship Structural Design: A Rational-based Computer Aided Optimization," *Publ. by John Wiley*, N.Y. (1983).